



"At Bartell, Customer Satisfaction is our business."

TAKE-UP CUSTOMER INQUIRY SPECIFICATION SHEET

CUSTOMER: CONTACT NAME: DATE: CONTACT PHONE:

PRODUCT DESCRIPTION:

Table with 4 columns: PRODUCT DIAMETER, PRODUCT WEIGHT PER FOOT, LINE SPEED RANGE MIN. TO MAX., TENSION RANGE MIN. TO MAX. (SEE NOTE BELOW). Rows for MINIMUM and MAXIMUM PRODUCT SPECIFICATIONS.

ON ABOVE CHART, SPECIFY THE UNITS USED (IN, MM, LB, KG, FPM, MPM)

NOTE: IF THE MAX TENSION IS UNKNOWN, FILL IN DIMENSIONS A, B, C USING THE DIAGRAM BELOW.

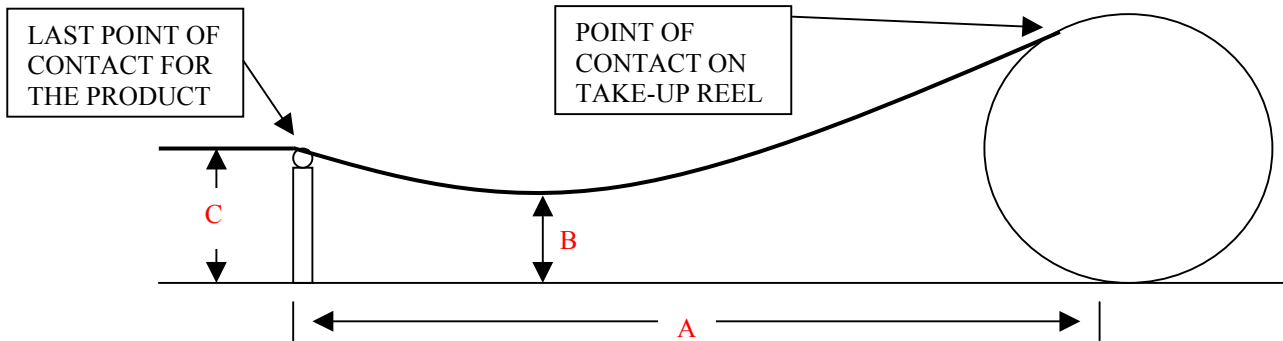

DIMENSIONS: A: B: C:

MACHINE STYLE: GANTRY PORTAL CANTILEVER OTHER STATIONARY MODEL TRAVERSING MODEL

ELECTRICAL REQUIREMENTS: VOLTS: PHASE: FREQUENCY: ISOLATION TRANSFORMER REQUIRED: YES NO TYPE OF APPLICATION: TENSION (TORQUE) SPEED WILL THE TAKE-UP NEED TO MAINTAIN ZERO SPEED: YES NO IS A DANCER REQUIRED: YES NO

FACTORY CONDITIONS: AIR PRESSURE (PSI) AMBIENT TEMP.



"At Bartell, Customer Satisfaction is our business."

REEL SPECIFICATIONS:

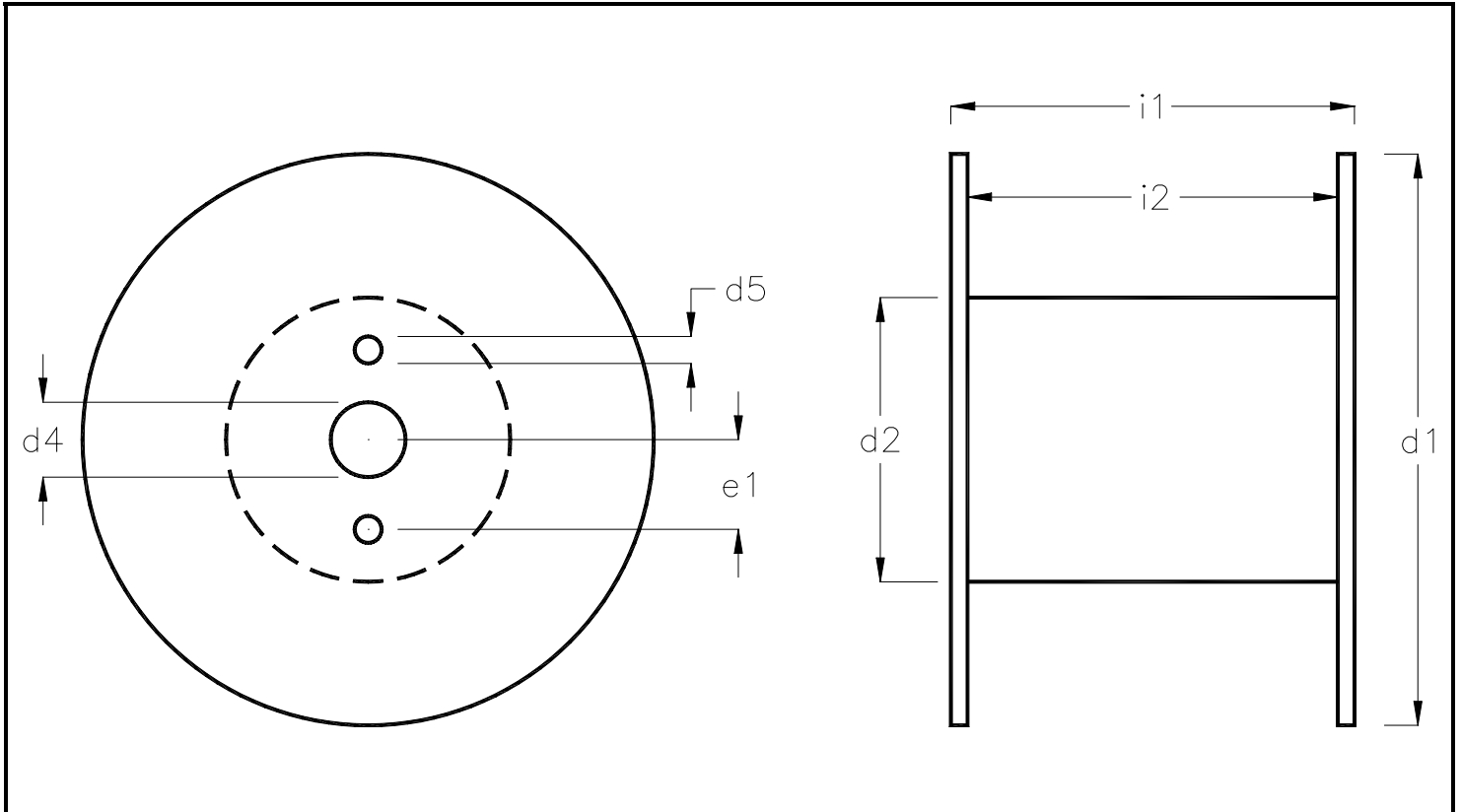

	d_1	d_2	d_4	d_5	i_1	i_2	e_1
SMALLEST REEL SPECIFICATIONS							
LARGEST REEL SPECIFICATIONS							

ON ABOVE CHART, SPECIFY THE UNITS USED (IN, MM)

LARGEST FULL REEL MAXIMUM WEIGHT: _____

PAINT SPECIFICATION:

MACHINE COLOR
 ROTATING PARTS

 GUARDS

 CABINETS & BOXES

STANDARD	CUSTOM
BARTELL BLUE	
SAFETY ORANGE	
SAFETY YELLOW	
BARTELL BLUE	

SPECIAL REQUIREMENTS:
