



PORTAL STYLE PAY-OFFS & TAKE-UPS

Our Portal style Pay-offs and Take-ups are designed for fast and easy loading and unloading of reels. The design features a rugged, compact, and a non-obtrusive framework. The Pay-offs and Take-ups are available in a traversing style and a stationary style, with pneumatically operated pintles. The machines are equipped with brake motors and ACME lifting screws for added safety. A wide variety of Cable Guide Stands, Dancers and Accumulators compliment this machine.

Take-up Standard Features:

- **Stationary model** with independent traverse.
- Advanced control system utilizing a plc controller, programmable operator interface, safety monitoring devices, and AC drives.
- State of the art traverse and reel drive train with a 2 year warranty.
- Holding brake.
- Easily adjustable cable guide roller assembly.
- Electro-mechanical lifting and positioning of reel.
- Full safety limits built in for pintle movements in lifting and lowering motions, prevents damage to machine and reel.
- On screen traverse adjustment, with features such as rapid traverse, pause traverse, and programmable flange delay.
- Ergonomically designed operator control stations.

Take-up Optional Features:

- **Traversing model.**
- Traversing model.
- Dancers / Accumulators for constant tension control.
- Movable cable guide stand.
- Movable dancer cable guide stand
- Auto-unload feature allows for the operator to push one button for the automatic discharge of a reel.
- Guarding packages.
- Pendant stations for operator controls.
- Remote radio operator controls, for maximum visibility and mobility.
- AC servo control of traverse.
- Transducer style traverse for precise traverse control and programmable turn around points.
- Custom designs available upon request.

Pay-off Standard Features:

- **Stationary model** with drag brake.
- Manually positioned through AC motors.
- Self locking lifting actuators.
- Full safety limits built in for pintle movements in lifting and lowering motions, prevents damage to machine and reel.

Pay-off Optional Features:

- **Automatic traversing model.**
- AC or DC driven models.
- Dancers / Accumulators for constant tension control.
- Auto-unload feature allows for the operator to push one button for the automatic discharge of a reel.
- Guarding packages.
- Pendant stations for operator controls.
- Remote radio operator controls, for maximum visibility and mobility.
- Electric braking.
- Jog capabilities.
- On board PLC for control purposes.
- Custom designs available upon request.



PORTAL STYLE PAY-OFFS & TAKE-UPS

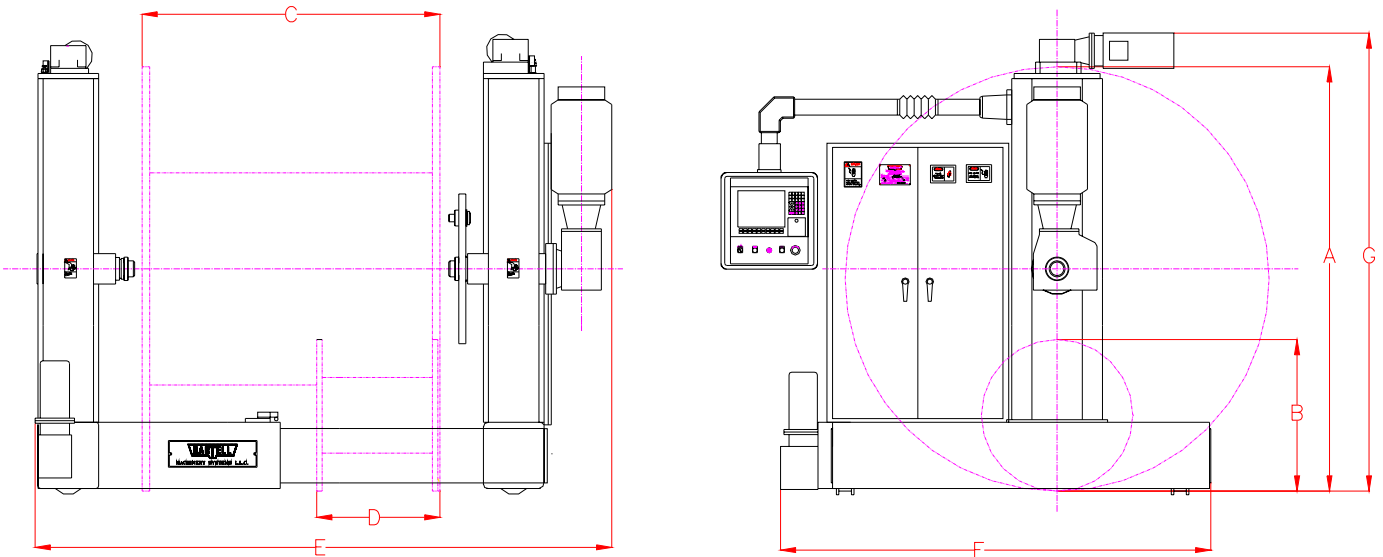

MACHINE MODELS								
TAKE-UP	TUP48	TUP60	TUP72	TUP84	TUP96	TUP108	TUP120	TUP180
PAY-OFF	POP48	POP60	POP72	POP84	POP96	POP108	POP120	POP180
DIMENSIONS								
INCHES / MILLIMETERS								
A	48/1219	60/1524	72/1829	84/2134	96/2438	108/2743	120/3048	180/4572
B	16/406	24/610	30/762	36/914	40/1016	48/1219	60/1524	84/2134
C	37/940	46/1168	52/1321	59/1499	75/1905	83/2108	89/2261	110/2794
D	12/305	19/482.6	24/610	26/660	29/737	37/940	46/1168	60/1524
E	54/1372	67/1702	81/2057	90/2286	106/2692	116/2946	122/3099	184/4674
F	60/1524	72/1829	84/2134	96/2438	108/2743	120/3048	132/3353	196/4978
G	54/1372	66/1676	78/1981	90/2286	102/2591	114/2896	126/3200	186/4724
LIFTING CAPACITIES								
1,000 - 88,000 POUNDS (454 - 39,916 KILOGRAMS)								

All specifications are subject to change without notice. Contact factory for up to date specifications. Custom designs are available upon request.