

GANTRY / BRIDGE STYLE PAY-OFFS & TAKE-UPS



Our Gantry/Bridge style of Pay-offs and Take-ups are different from any of the other styles of machines mainly because the lift arms are supported by rails on the top of the frame. They are available as traversing or stationary reel machines. The traversing machine has the lift arms and the reel traversing side to side, while the frame is stationary. On the stationary machine, the arms move only as much as is required for the loading and unloading of the reels. The stationary machine has its own traverse assembly that lays the product onto the reel.

Take-up Standard Features:

- **Stationary model** with independent traverse.
- Advanced control system utilizing a plc controller, programmable operator interface, safety monitoring devices, and AC drives.
- State of the art traverse and reel drive train with a 2 year warranty.
- Holding brake.
- Easily adjustable cable guide roller assembly
- Electro-mechanical lifting and positioning of reel.
- Full safety limits built in for pintle movements in lifting and lowering motions, prevents damage to machine and reel.
- On screen traverse adjustment, with features such as rapid traverse, pause traverse, and programmable flange delay, programmable turn around points.
- Ergonomically designed operator control stations.

Take-up Optional Features:

- **Traversing model.**
- Dancers and Accumulators for constant tension control.
- Guarding packages.
- Pendant stations for operator controls.
- Remote radio operator controls, for maximum visibility and mobility.
- AC servo control of traverse.
- Movable cable guide stands.
- Movable dancer cable guide stands.
- Auto-unload feature allows for the operator to push one button for the automatic discharge of a reel.
- Custom designs available upon request.

Pay-off Standard Features:

- **Stationary model** with pneumatic disc brake for tension control.
- Ergonomically designed operator control stations.

Pay-off Optional Features:

- **Traversing model.**
- AC or DC driven model.
- Dancers / Accumulators for constant tension control.
- Auto-unload feature allows for the operator to push one button for the automatic discharge of a reel.
- On board PLC for control purposes.
- Guarding packages.
- Pendant stations for operator controls.
- Remote radio operator controls, for maximum visibility and mobility.
- Electric braking.
- Jog capabilities.
- Custom designs available upon request.



GANTRY / BRIDGE STYLE PAY-OFFS & TAKE-UPS

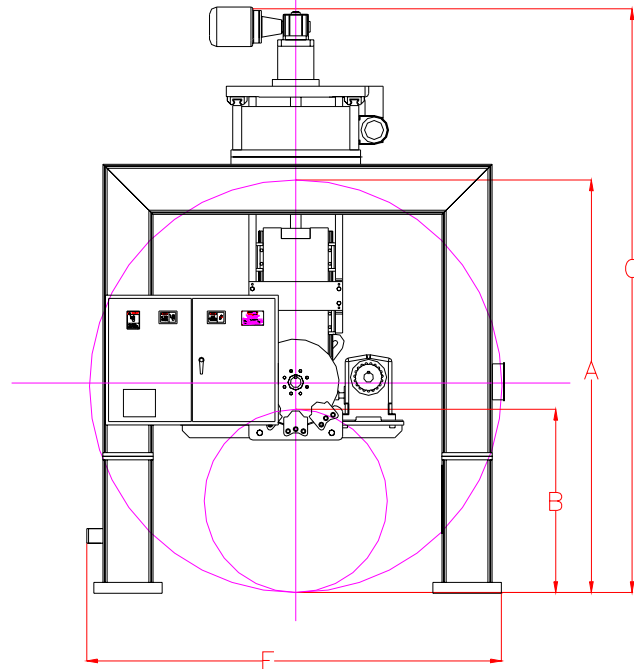
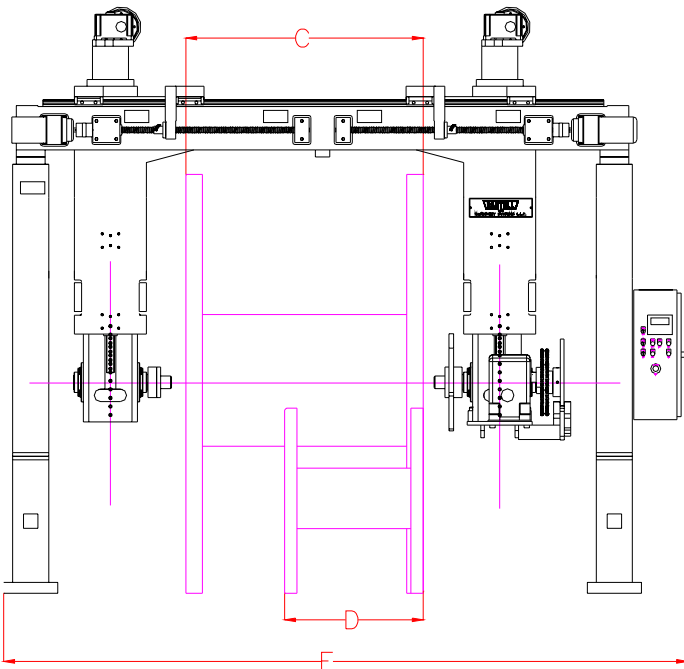

MACHINE MODELS							
TAKE-UP	TUG48	TUG60	TUG72	TUG84	TUG96	TUG108	TUG120
PAY-OFF	POG48	POG60	POG72	POG84	POG96	POG108	POG120
DIMENSIONS	INCHES / MILLIMETERS						
A	48/1219	60/1524	72/1829	84/2134	96/2438	108/2743	120/3048
B	16/406	24/610	30/762	36/914	40/1016	48/1220	60/1524
C	37/940	46/1168	52/1320	59/1499	75/1905	83/2108	89/2261
D	12/305	19/483	24/610	26/660	29/737	37/940	46/1168
E	112/2845	121/3124	191/4851	210/5334	226/5740	234/5944	238/6045
F	67/1702	79/2007	91/2311	116/2946	121/3124	121/3124	134/3404
G	102/2591	115/2921	127/3226	139/3531	151/3835	163/4140	175/4445
LIFTING CAPACITY							
1,000 - 88,000 POUNDS (454 - 39,916 KILOGRAMS)							

All specifications are subject to change without notice. Contact factory for up to date specifications. Custom designs are available upon request.